

WD-L series

Size WD-L 0478 / 1-row / 1 drive

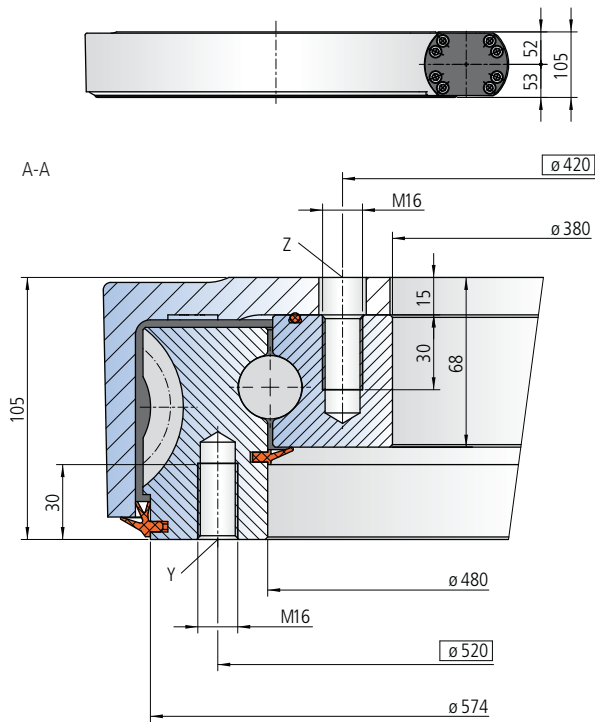

The mounting structure must support the housing to at least $\varnothing 478$

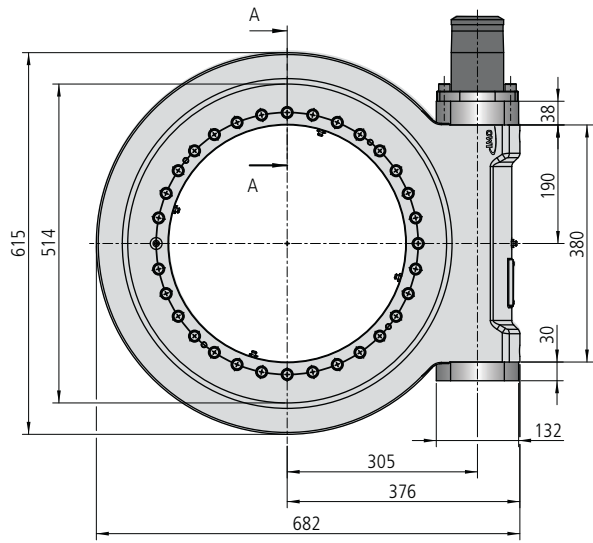

Mounting holes

Y = 32 drill holes M16-30 deep, evenly distributed

Z = 31 drill holes $\varnothing 19$ -15 deep / M16-30 deep, evenly spaced over 32 pitch

Lubricating ports

4 conical grease nipples on internal diameter

1 conical grease nipple on housing exterior

Slew drive supplied pre-lubricated

Drawing number WD-L 0478/3-10090				
Drawing number WD-L 0478/3-04904				
Module	m	[mm]	6	6
Number of threads of the worm		[-]	1	2
Gear ratio	i	[-]	93	47
Self-locking gears			No**	No**
Max. torque $s_f = 1$	M_{d max}	[Nm]	24288	24288
Nom. torque $s_W = 1$ at $n = 1 \text{ min}^{-1}$	M_{d nom}	[Nm]	24288	24288
Max. holding torque* $s_{FS} = 1$ (static)	M_{h max}	[Nm]	34263	34263
Static load rating, radial	C_{o rad}	[kN]	675	675
Static load rating, axial	C_{o ax}	[kN]	1808	1808
Dynamic load rating, radial	C_{rad}	[kN]	251	251
Dynamic load rating, axial	C_{ax}	[kN]	293	293
Weight, incl. 12 kg for hydraulic motor RE 300		[kg]	139	139

* Optionally with brake

** See: Technical Information, section *Self-locking*

The hydraulic/electric motor is selected according to the actual requirements and customer specification.

Selection example:

Performance data with hydraulic motor RE 300

Pressure differential	Δp	[bar]	120	200
Oil flow	Q	[l/min]	33	22
Output speed	n	[min ⁻¹]	1	1
Max. achievable torque	M_d	[Nm]	24288	24288

Limiting load diagram for compressive loads

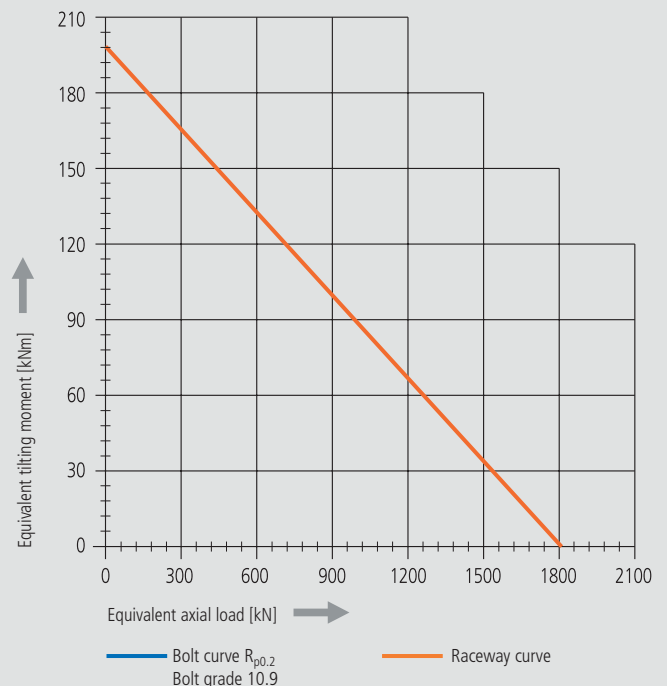

Please always observe the technical information!